



# Centrifugal fans

## EBB-N Series

### EBB-100



**2**  
SPEED

The EBB-N extractor fans are suitable for many domestic and commercial ventilation applications where higher system resistance pressures are encountered. The range comprise of three models, EBB-100N, EBB-170N and EBB-250N, each available in different versions. The EBB-N models incorporate a forward curved centrifugal impeller with 2-speed single phase motor 230V50Hz, 4-pole (EBB-170N and 250N) or 2-pole motor (EBB-100N). IP44. Class II. Housing and impeller made in polypropylene. Suitable to operate with air temperature up to 40°C.

### + Attributes

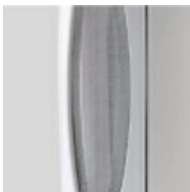

**Filters**  
Two metal filters (inox for models 170 and 250) that keep out dust and dirt in the exhaust.



**Back draft shutter**  
The EBB-N are fitted with an automatic back draft shutter to prevent air entry and limit heat leakage when the extractor is not operating.



**2 Back draft shutter**  
2 back draft shutter of Ø80 and Ø100 mm.



**Forward curved centrifugal impeller**  
To deliver high performance with a minimum noise level against high static pressure system resistance.

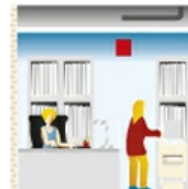

### + Installation

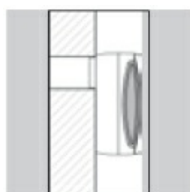

Surface

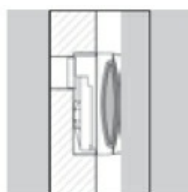

Built-in

## + Features

	S	T	HT
BACK DRAFT SHUTTER	EBB-170 N / EBB-250 N	EBB-170 N / EBB-250 N	EBB-170 N / EBB-250 N
2 BACK DRAFT SHUTTER	EBB-100 N	EBB-100 N	EBB-100 N
METAL FILTERS	EBB-100 N	EBB-100 N	EBB-100 N
INOX FILTERS	EBB-170 N / EBB-250 N	EBB-170 N / EBB-250 N	EBB-170 N / EBB-250 N
TWO SPEED	●	●	●
ADJUSTABLE RUN-ON-TIMER		●	●
INTERNAL HUMIDISTAT			●

## + Technical characteristics

Model	Speed (r.p.m.)		Abs. power at free discharge (W)	Voltage (V) 50Hz	Sound pressure level* (dB(A))	Airflow at free discharge (m³/h)	IP	Ø duct (mm)	Weight (Kg)
	VR	VL							
EBB-100 N	VR	1600	35	230	46	130	Class II / IP44	100/80	1,8
	VL	1050	15	230	34	75			
EBB-170 N	VR	1100	48	230	42	220	Class II / IP44	100	3
	VL	780	36	230	32	140			
EBB-250 N	VR	1225	51	230	46	270	Class II / IP44	100	3
	VL	900	36	230	38	190			

\* At a distance of 1,5 m.

## + Dimensions

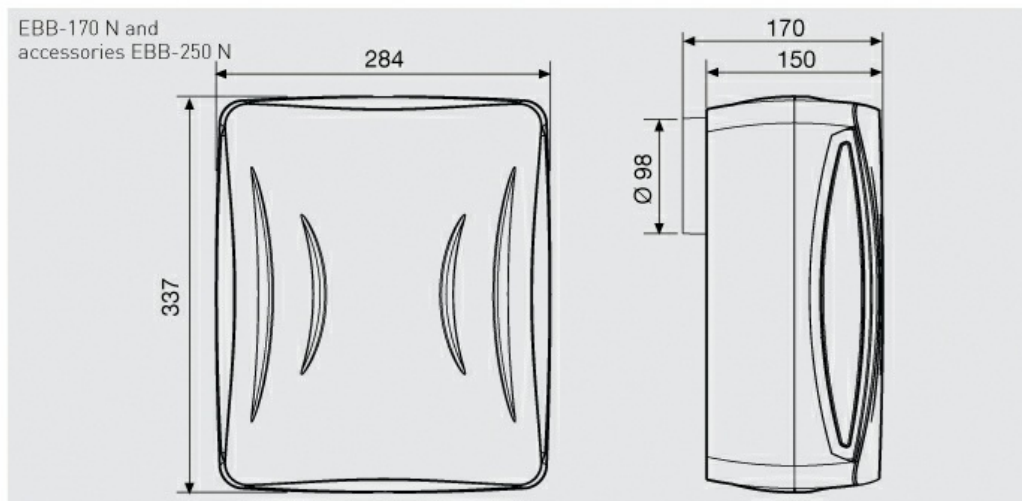
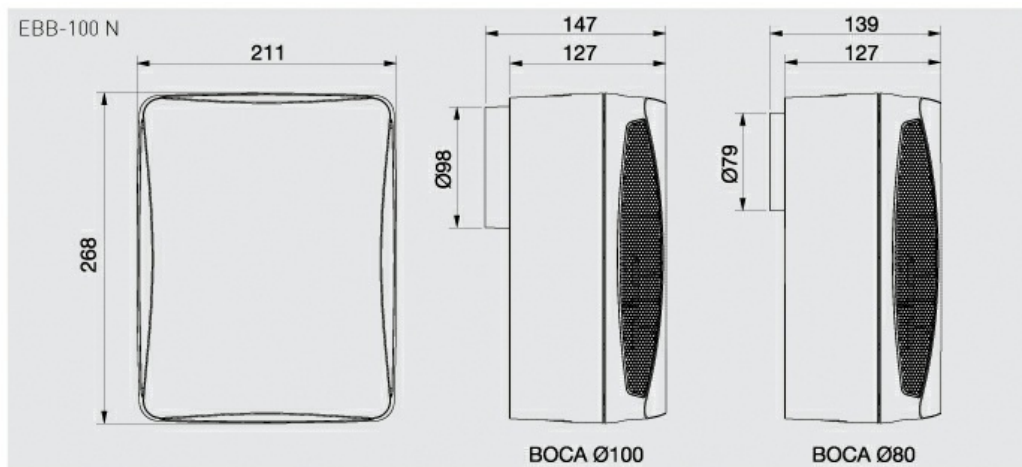

## + Curves

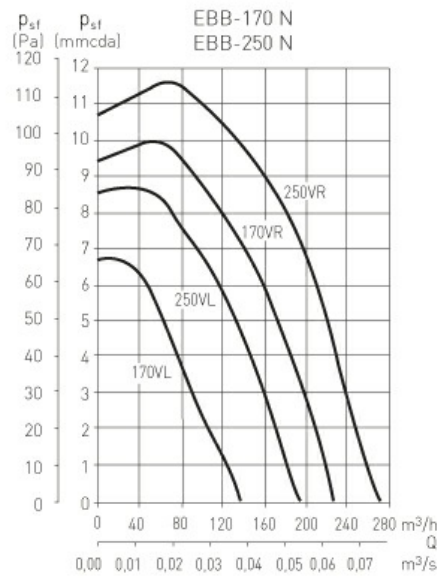
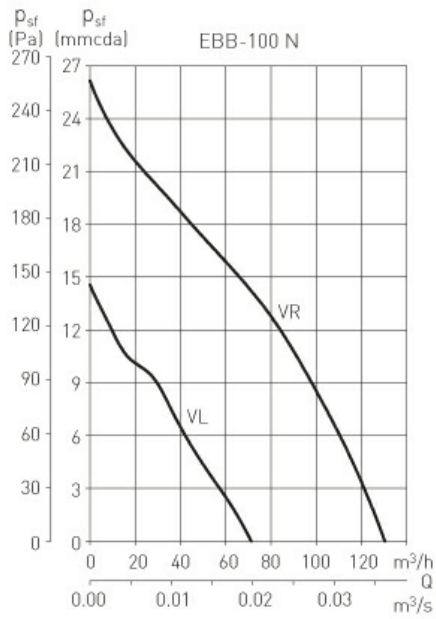

## + Mounting Accessories



**GSA-100**  
Flexible aluminium ducting.



**GRA-75**  
Aluminium external grille.



**MRT-100**  
Circular duct joining piece.



**CX-80/125**  
Worm drive ducting clip.



**REB**  
Single phase electronic speed controllers.



**REGUL-2**  
Two speed switch.