



Bathroom extract fans

SILENT-100 DESIGN

3C Series

SILENT-100 DESIGN



Range of axial extractors with airflow rates of approx. 85 m³/h, for connection to 100 mm diameter circular ducting. Motor mounted on silent-elastic-blocks which absorb the vibrations and allow offering very low noise level. All the fans are manufactured from injection moulded plastic, fitted with automatic shutter and single phase 230V-50Hz, class B low consumption motor equipped with thermal overload protection. All the fans are class II insulation, IP45 rated and suitable to operate with air temperature up to 40°C.

+ Attributes



Back draft shutter

To prevent air entry and limit heat leakage when the extractor is not operating. It opens due to the pressure of the air.



Silent-blocks

Motor mounted on "Silent-elastic-block" to prevent vibration and noise transmission.

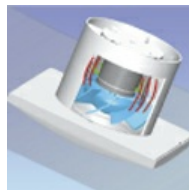

SILENT-100 DESIGN

Quiet operation

In usual extract fans the vibrations are transmitted to the surrounding areas while in SILENT extractor fans the vibrations are absorbed by the Silent Blocks.



USUAL EXTRACTOR



Interchangeable bars colours

Interchangeable bars colours let the fan blend in with every setting. 4 colours to match the decor of the room: blue, red, green and yellow.

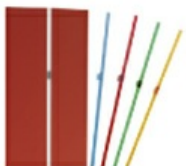

SILENT-100 CZ DESIGN

4C: Different colours available.

4C models incorporate 5 interchangeable bars colours (white, clear, blue, green, red and yellow).



Models 3C



Black

Grey

Champagne

Gold



Ivory

Red

Marble white

Marble black

+ Features

	CZ DESIGN 3C	CRZ DESIGN 3C	CHZ DESIGN 3C	CZ SILVER DESIGN 3C	CRZ SILVER DESIGN 3C	CHZ SILVER DESIGN 3C
PILOT LIGHT	•	•	•	•	•	•
BACKDRAFT SHUTTER	•	•	•	•	•	•
ADJUSTABLE RUN-ON-TIMER (1-30MIN)		•	•		•	•
ADJUSTABLE HUMIDISTAT			•			•
BALL BEARINGS	•	•	•	•	•	•
SILVER COLOUR				•	•	•
KIT BAR LIGHTS 4 COLOURS	•	•	•	•	•	•

+ Technical characteristics

Model	Abs. power at free discharge (W)	Voltage (V) 50 Hz	Sound pressure level* (dB(A))	Airflow at free discharge (m ³ /h)	Insulation/ IP	Ø duct (mm)	Weight (Kg)
SILENT-100 DESIGN 3C	8	230	26,5	85	Class II / IP45	100	0,65
KIT SILENT-100 DESIGN 12V** 3C	12	12	26,5	80	Class III / IP57	100	0,65

* Sound pressure level measured at 3 m at free air conditions.

** Delivered with CT-12/14 transformer.

+ Dimensions

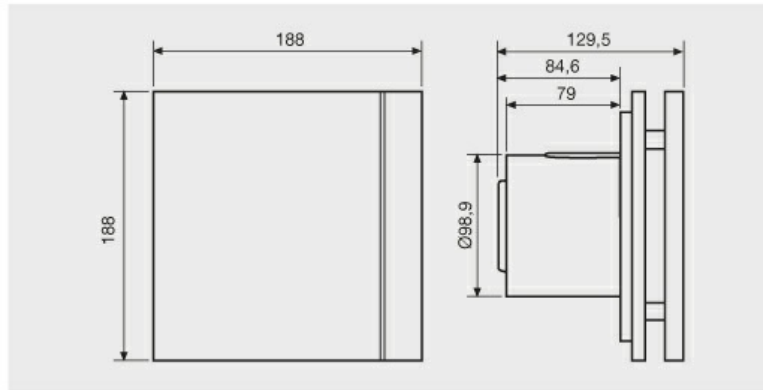

+ Curves

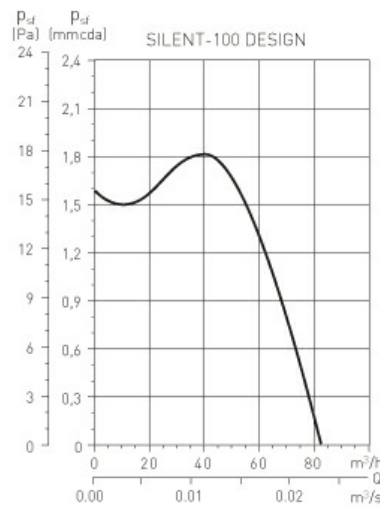

+ Mounting Accessories



GSA-100
Flexible aluminium ducting.



GRA-75
Aluminium exterior grille.



WALL KIT
Fixed shutter and telescopic duct. (200 to 420 m).



CX-80/125
Worm drive ducting clip.



PER-100W
Back draft shutter.



WINDOW KIT 100
Accessory to allow SILENT-100 in a window.