

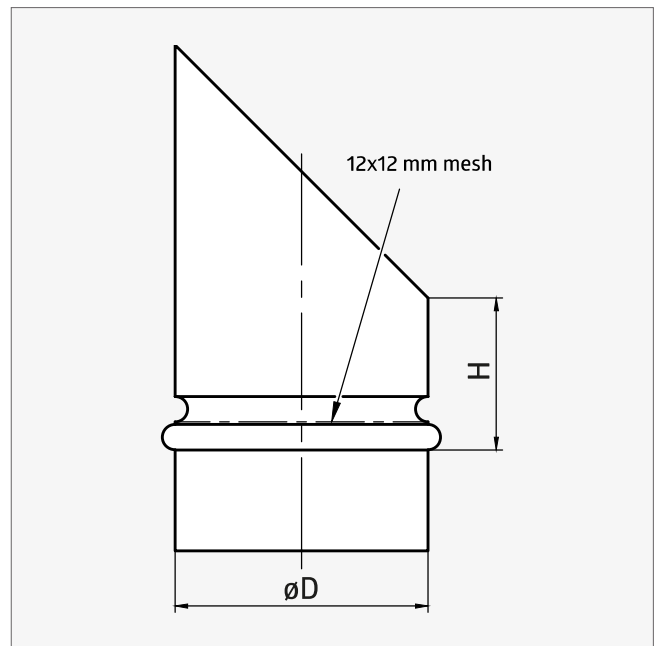

Angle take-off with mesh **AV(E) / AVL**



PRODUCT CHARACTERISTICS:

- mesh mounted by spot welding
- stitch welded
- produced with returned (AV/AVL) or sharp edges (AVE)
- gasket is positioned by returned edges (AVL)

MATERIAL:

- galvanized steel
- 12×12 mm mesh
- EPDM rubber gasket (AVL)

øD [mm]	H [mm]		
		AVE	AV / AVL
80	60		
100	60	65 P4	30 P12
125	60	50 P4	27 P12
140	60	30 P4	
150	60	30 P4	10 P12
160	60	60 P2	10 P12
180	60	50 P2	
200	60	50 P2	12 P6
224	60	30 P2	
250	60	30 P2	5 P6
280	60	28 P1	
315	60	28 P1	5 P6
355	60	24 P1	4 P6
400	50	15 P1	4 P4
450	50	9 P1	
500	50	8 P1	
560	60	6 P1	
630	60	4 P1	

 Packaging [pcs | type]