

SmartAir SADP70

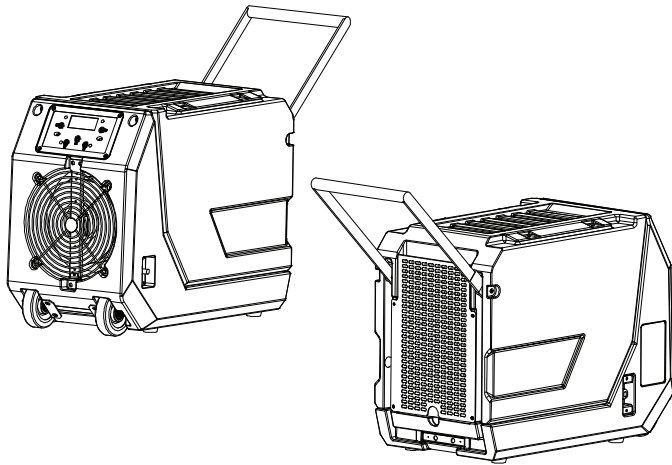

PRODUCT	W	D	H
SADP70	610 mm	338 mm	497 mm

Catalog#	SADP70		
Power Supply	220-240V~ 50Hz		
Dehumidifying Capacity	70L/day(30°C RH80%) 45L/day (27° RH60%)		
Power	987W		
Air Volume	- High	663 m ³ /hr	
	- Low	544 m ³ /hr	
Noise Level	≤55dB(A)		
Operating Temperature	1-38°C		
Operating humidity range	10%RH-90%RH		
Power cord	7.5m		
Refrigerant	R410a		
Net Weight	33.8 kg		
Gross Weight	37.1 kg		
Product Size(W × D × H)	610 × 338 × 497 mm		
Packing Size(W × D × H)	710 × 400 × 550 mm		

Loading quantity (pallet)	24
Loading Quantity 20'GP	176pcs
Loading Quantity 40'GP	348pcs
Loading Quantity 40'HQ	348pcs

Automatic shut-off when water level full	✓
Control board	LED screen/keys
Timer	✓
Drain option	✓
Laundry drying program	✓
Memory	✓
Integrated pump	✓
Drain hose diameter	2.5m
Integrated hygrometer	✓
Stackable	✓
Working hours meter	optional
Washable dust filter	✓
Optional accessory	✗
folding handle	✓
Ducting connections	4 meter water pipe
Water pump max. drain length	4M
Water pump max. drain height	4M
Child lock function	✗
Calendar Programming	✗



